

Grove YB7725

Product Guide



Features

- 22 t (25 USt) capacity
- 21,6 m (71 ft) four-section full power boom
- 13,6 t (15 USt) deck carrying capacity
- Tilt steering wheel
- Load sensing piston hydraulic pump
- Proportional hydraulic controls



Features



The reach and capacity to get the job done

A 5,1 m (17 ft) swingaway extension added to the 21,6 m (71 ft) main boom provides an impressive 28,9 m (95 ft) tip height with a capacity of 2268 kg (5000 lb). A galvanized down-haul ball is included with the extension.



Hook block

A galvanized coated hook block is provided as standard to help eliminate rusting of this important crane component.

Split door design

The “new” split door design, offered with the optional enclosed cab, allows for the top half to be left open while keeping the bottom half closed for safety.



Operator cab

Hydraulic proportional joystick controls, automotive dash layout, tilt steering wheel, and suspension seat enhances operator comfort and ease of use.

Contents

| | |
|-----------------------|----|
| Specifications | 4 |
| Dimensions | 7 |
| Range diagram | 9 |
| Load chart | 10 |
| DIN/ISO range diagram | 12 |
| DIN/ISO load chart | 13 |
| Symbols glossary | 15 |

Specifications

Superstructure

Boom

7,21 m – 21,6 m (23 ft 8 in - 71 ft) full power main boom. Four-section boom with three (3) powered sections.

Maximum tip height: 24,0 m (79 ft).

*Offsettable swingaway extension

5,1 m (17 ft) offsettable swingaway extension. Offsets 0°, 15°, and 30° via pivoting boom nose. Stows alongside base boom section.

Maximum tip height: 28,9 m (95 ft).

Boom nose

Two nickel plated steel sheaves mounted on heavy duty tapered roller bearings with removable pin-type rope guards. Quick reeve type boom nose with four-position (0°, +30°, +60°, and + 80°) pivoting to minimize head height requirements. Lowers head height by 0,6 m (2 ft).

Boom elevation

Two double acting hydraulic cylinders with integral holding valves provides elevation from -0° to +80°.

Anti-two block device

Standard anti-two block device, which, when activated, provides an audible warning to the operator and “locks-out” all functions whose movement can cause two-blocking.

Load indicator (LSI)

A simple effective and easy to use load indicating system used in conjunction with the anti-two block system to assist the operator in efficient operation of the unit within the limits of the load chart. The display panel displays the hook load and cuts-out the telescope and boom lift down function when a load limit is exceeded. The warning is by a flashing light on the display panel. In conjunction with the load display panel (receiver) there is a wireless transmitter and load sensing pin attached to the boom head that transmits the hook load to the display panel.

(**wireless system**)



*Load Moment Indicator (LMI)

“Graphics Display” of boom angle, boom length, boom radius, capacity, and allows for operator input to set the limit parameters based on the load chart. Displays color coded light bar and audible alarm with function cut-out if load exceeds the load chart parameters.

(**hardwired system**)



Swing

Ball bearing swing circle with 360° continuous rotation. Hydraulic motor driven pinion with brake. Maximum speed: 2.5 rpm



Hydraulic system

One pressure compensated variable displacement axial piston pump with load sensing combined with two (2) gear pumps.

Maximum output of: 238 LPM (79 GPM).

Maximum operating pressure: 248 bars (3600 psi).

Six section valve bank, chassis mounted, operated via dash mounted, pilot pressure hydraulic joysticks. 227 L (60 gal) hydraulic reservoir with sight level gauge and steel side plating to guard against side impacts.

10 micron return line filter with full flow by-pass protection and service indicator.



Hoist specifications

Piston motor driven with automatic spring applied / hydraulically released wet brake.

Maximum hoist pull (first layer): 6804 kg (15,000 lb)

Maximum permissible single line pull:
5670 kg (12,500 lb) (3.5:1 design factor)

Maximum single line speed: 61 m/min (200 fpm)

Rope construction: 6X19 XIPS/IWRC

Rope diameter: 16 mm (5/8 in)

Rope length:
Main hoist: 119 m (390 ft)

Maximum rope stowage:
Main hoist: 151 m (495 ft)

Specifications

Carrier



Chassis

High strength alloy frame constructed with integral outrigger housings; front and rear lifting, tie-down, and towing lugs. 60 ft² carrydeck size with 13 608 kg (30,000 lb) deck only carrying capacity. Deck coated with anti-skid treatment.



Outriggers

Two-stage hydraulic telescoping beam with vertical jack at the four corners provides extended and down and retracted and down lifting capacities. Integral holding valves on both beam and jack cylinders.

Outrigger pad size:

29,2 cm x 29,2 cm (11.5 in x 11.5 in)

Maximum outrigger pad load:

20 321 kg (44,800 lb) / 339 p.s.i.



Outrigger controls

Independent outrigger control rocker switches for beam or jack selection with separate extend/retract rocker switch. 360° bubble level located inside cab.



Engine (Tier IV)

Cummins QSB 4.5 L, four cylinders, turbo-charged diesel rated at 974 kW (130 hp) at 2500 rpm. Standard 110V engine block heater and cold weather intake grid heater.

Diesel Oxidation/Catalyst, stainless steel, muffler to meet 2012 EPA emissions, combined with a Cummins direct air flow, 2 stage cyclonic air filter system.

Maximum torque: 620 N-m (457 ft lb) at 1500 rpm.

Note: Tier IV engine Required in North American and European Union countries.



Engine (Tier III)

Cummins QSB 4.5L, four cylinders / turbo-charged diesel rated at 974 kW (130 bhp) (Gross) at 2500 rpm. Standard 110V engine block heater and cold weather “ether” assist system. Engine hour meter located inside operators compartment.

Maximum torque: 370 N-m (273 ft lb) at 2500 rpm.

Note: Required for sale outside of North American and European Union countries



Fuel tank capacity

189 L (50 gal)



Transmission

Powershift with four speeds forward and reverse. Stalk mounted direction shifter with rotary gear selection.



Operators control station

Frame mounted, open air style control station with cab shell includes all crane functions, driving controls, and overhead safety glass. Other standard equipment includes a suspension seat with seat belt, hourmeter, sight level bubble, and 2.5 lb (1.1 kg) fire extinguisher. The dash panel includes a multi-cluster gauge showing fuel, water temperature, oil pressure, and battery voltage. An engine monitoring indicator strip shows engine warning, stop engine, transmission low pressure, transmission high temperature, and low brake system pressure. The load indicator receiver is mounted to the top of the dash panel.



*Operators control station enclosed

Includes the standard cab shell with the addition of front, rear, and right side glass, a split (2 piece) hinged door with sliding glass, front windshield wiper and washer, hot water heater and defroster with fan and cab dome light are included.



Electrical system

Two 12V maintenance-free batteries, 820CCA at 0°. 63 amp alternator.



Drive

2 wheel (rear drive) or 4 wheel selection, front and rear axle drive with planetary hubs and limited slip differential.



Steer

Standard three steering modes. Front two wheel, four-wheel coordinated, and four-wheel crab steer with electronic self alignment, three-position rocker selector on dash panel.

Outside turning radius:

Two-wheel steer: 7,32 m (24 ft)

Four-wheel steer: 4,04 m (13 ft 3 in)

Specifications

Carrier continued



Suspension/axles

Front: Drive/steer with differential and planetary reduction hubs, axle is rigid mounted to frame.

Rear: Drive/steer with differential and planetary reduction hubs, axle is pivot mounted to frame allows up to 3.5° of oscillation.



Oscillation lockouts

Manual switch to engage and disengage the rear axle lockouts. Engage when lifting on rubber and in crab steer mode, Disengage to allow oscillation when traveling over rough terrain.



Brakes

Hydraulic actuated internal wet-disc service brake acting on all four wheels. Dash mounted toggle switch with light for activating or release of the dry disc parking brake mounted on the transmission output yoke.



Tires

Standard: 17.5 x 25 Bias

Optional: 17.5R25 radials



Lights

Full lighting including turn indicators, head, tail, brake and hazard warning lights recessed mounted.



Maximum speed

31,3 km/h (19.5 mph)



Gradeability (theoretical)

63%..... (at engine stall) NO LOAD

38%.....(at engine stall) with 13 608 kg (30,000 lb)

DECK LOAD

Gross vehicle weight (G.V.W.)

Open cab: 20 249 kg (44,640 lb)

Enclosed cab: 20 354 kg (44,873 lb)

Miscellaneous standard equipment

22 t (25 USt) Two sheave “galvanize coated” hook block, with “Quick Reeve”.

Back-up motion alarm

Outrigger motion alarm

Dual rear-view mirrors

*Optional equipment

- ▶ **AUXILIARY LIGHTING:** includes cab mounted amber flashing light, dual base boom mounted floodlights
- ▶ **CONVENIENCE PACKAGE:** includes front and rear pintle hitch and headlight/taillight grille covers
- ▶ **ENCLOSED CAB PACKAGE:** includes heater and defroster, cab dome light, all window glass, and two piece split door
- ▶ 5,2 m (17 ft) fixed extension
- ▶ Air conditioner
- ▶ Catalytic convertor
- ▶ Hoist drum rotation indicator
- ▶ Wire rope 3rd wrap indicator with hoist function cut-out
- ▶ 3629 kg (8000 lb) below deck mounted tow winch
- ▶ Foam – filled tires

Dimensions

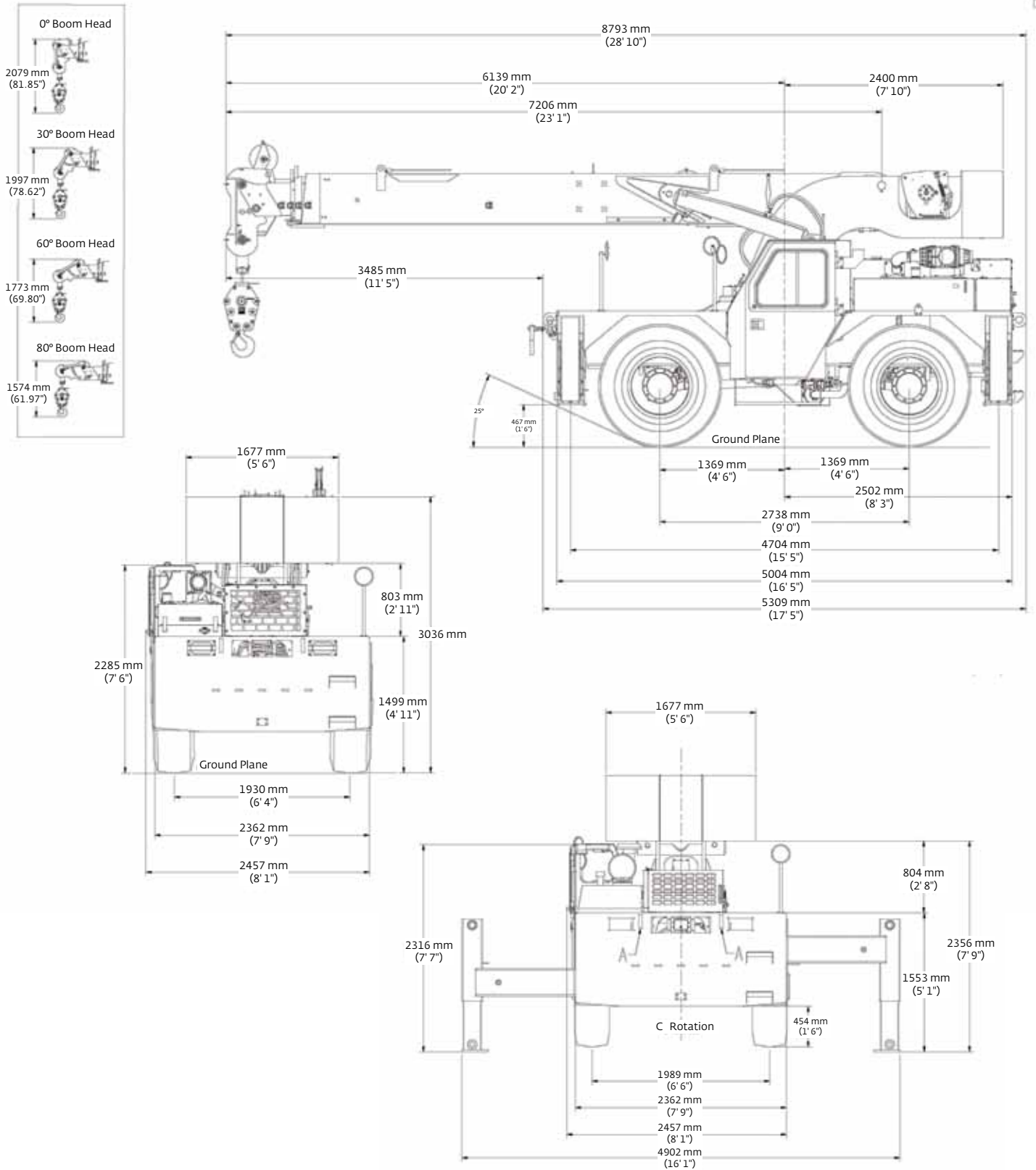

Dimensions

| Dimensions | | | | | | |
|---------------|-----------|------------|-------------|------------|------------|------------|
| | Tire size | A | B | C | D | E |
| 2-wheel steer | 17.5 x 25 | 19 568 mm | 16 093.4 mm | 15 240 mm | 14 600 mm | 9326.9 mm |
| | | (770.4 in) | (633.6 in) | (600 in) | (574.8 in) | (367.2 in) |
| 4-wheel steer | 17.5 x 25 | 14203.7 mm | 9936.5 mm | 9083 mm | 8168.6 mm | 3779.52 mm |
| | | (559.2 in) | (391.2 in) | (357.6 in) | (321.6 in) | (149 in) |

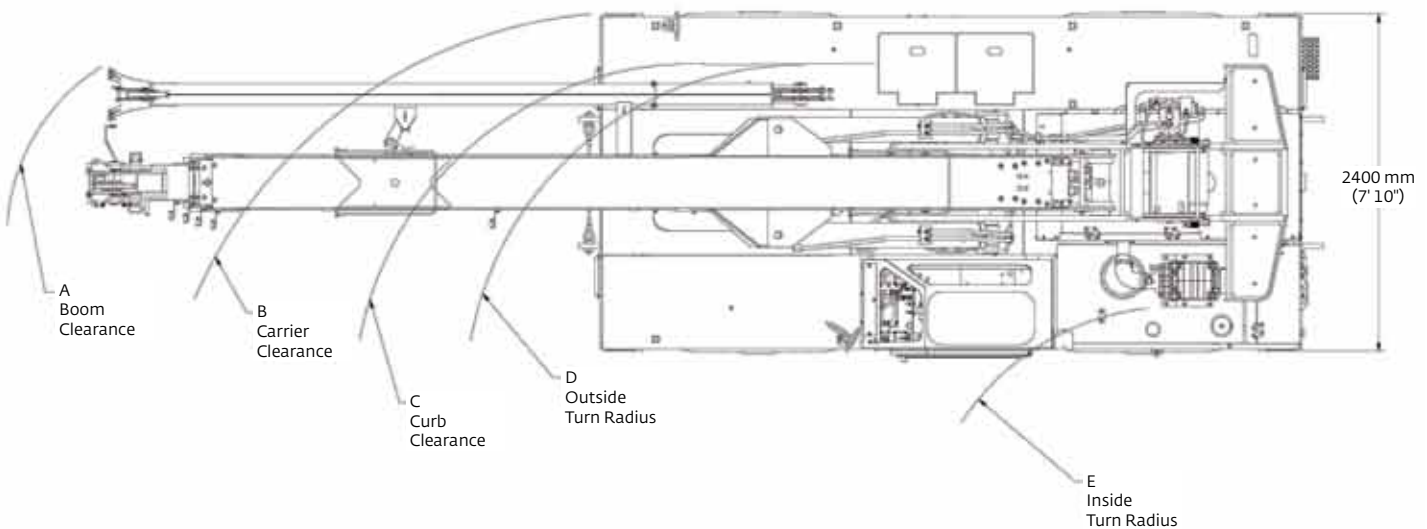

| Weights | | | | | | |
|--|--------|----------|--------|----------|--------|----------|
| | GVW | | Front | | Rear | |
| | kg | (lb) | kg | (lb) | kg | (lb) |
| Basic machine: Including 21,6 m (71 ft) main boom, main hoist with 119 m (390 ft) of wire rope, 22,6 t (25 USt) hookblock, full counterweight, Tier IV engine | 20 249 | (44,640) | 9 904 | (21,834) | 10 345 | (22,806) |
| Add: 5,1 m (17 ft) fixed swingaway extension and extension carrier brackets and downhaul weight | 208 | (458) | 406 | (896) | -199 | (-438) |
| Crane weight | 20 456 | (45,098) | 10 310 | (22,730) | 10 146 | (22,368) |
| Basic machine: Including 21,6 m (71 ft) main boom, main hoist with 119 m (390 ft) of wire rope, 22,6 t (25 USt) hookblock, full counterweight, Tier IV engine | 20 249 | (44,640) | 9 904 | (21,834) | 10 345 | (22,806) |
| Add: Enclosed cab with heater and defroster | 106 | (233) | 104 | (104) | 129 | (129) |
| Crane weight | 20 354 | (44,873) | 9 951 | (21,938) | 10 403 | (22,935) |

Range diagram

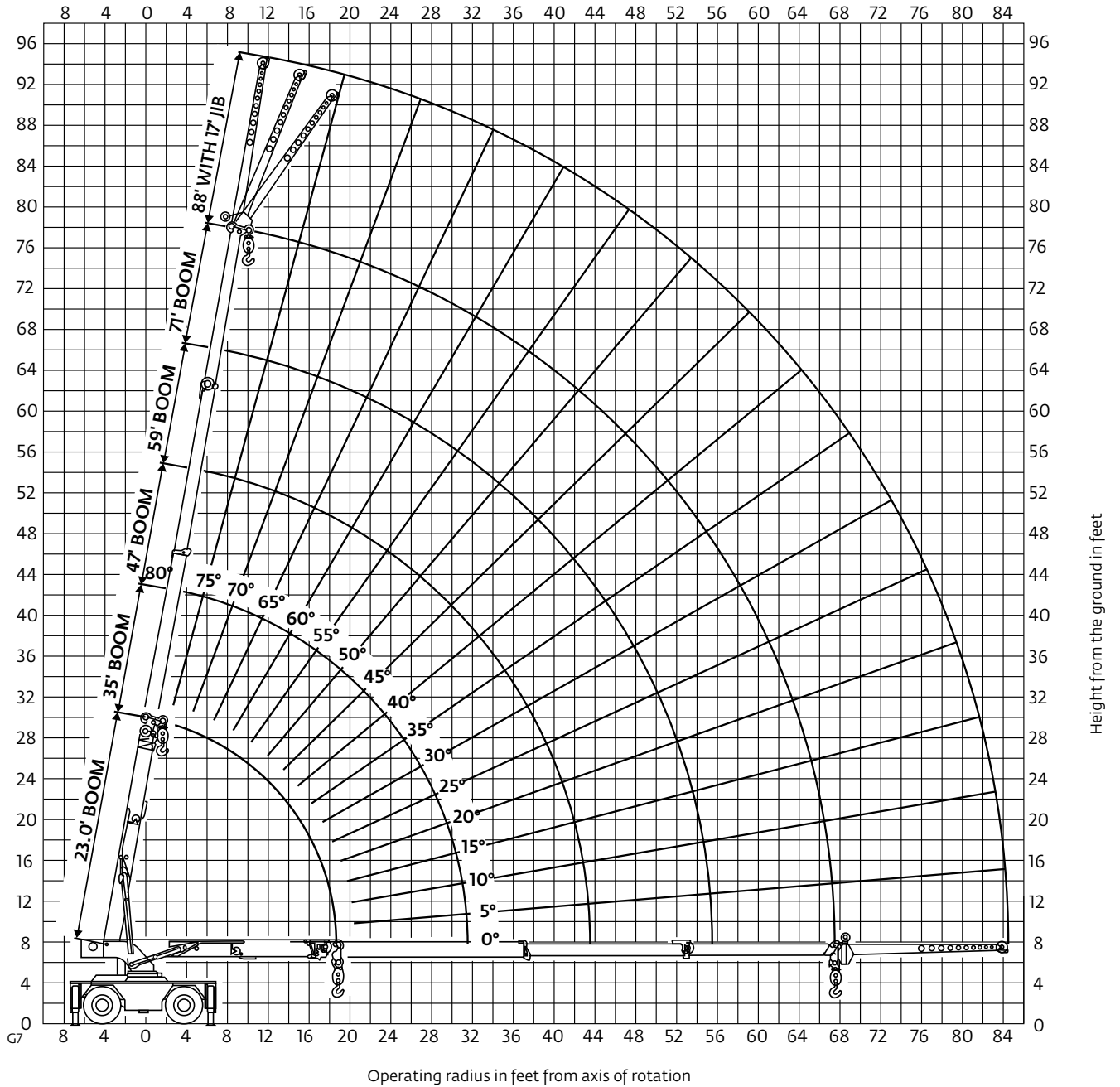

THIS CHART IS ONLY A GUIDE AND SHOULD NOT BE USED TO OPERATE THE CRANE.
 The individual crane's load chart, operating instructions and other instructional plates must be read and understood prior to operating the crane.

Load chart

| MAIN BOOM LOAD RATINGS ON OUTRIGGERS Extended and Down 360° or Retracted and Down Front/Rear | | | | | | | | | | | MAIN BOOM LOAD RATINGS ON OUTRIGGERS Retracted and Down 360° | | | | | | | | | | | |
|---|------------------------|-----------------------|------------------------|-----------------------|------------------------|-----------------------|------------------------|-----------------------|------------------------|-----------------------|---|------------------------|-----------------------|------------------------|-----------------------|------------------------|-----------------------|------------------------|-----------------------|------------------------|-----------------------|-----|
| Radius (ft) | 23.0 ft Boom | | 35.0 ft Boom | | 47.0 ft Boom | | 59.0 ft Boom | | 71.0 ft Boom | | Radius (ft) | 23.0 ft Boom | | 35.0 ft Boom | | 47.0 ft Boom | | 59.0 ft Boom | | 71.0 ft Boom | | |
| | Boom Angle (deg) | Rated Load (lb) | Boom Angle (deg) | Rated Load (lb) | Boom Angle (deg) | Rated Load (lb) | Boom Angle (deg) | Rated Load (lb) | Boom Angle (deg) | Rated Load (lb) | | Boom Angle (deg) | Rated Load (lb) | Boom Angle (deg) | Rated Load (lb) | Boom Angle (deg) | Rated Load (lb) | Boom Angle (deg) | Rated Load (lb) | Boom Angle (deg) | Rated Load (lb) | |
| 8.5 | 64.2 | 50,000 | 73.2 | 34,300 | 78.1 | 33,600 | 79.7 | 27,800 | | | 8.5 | 63.5 | 26,350 | 73 | 24,000 | 78 | 21,900 | | | | | |
| 10 | 59.8 | 38,793 | 70.6 | 34,500 | 76.2 | 33,017 | | | | | 10 | 59 | 20,800 | 70.5 | 19,300 | 76 | 17,900 | | | | | |
| 12 | 53.6 | 34,893 | 66.9 | 31,426 | 73.6 | 29,285 | 77.8 | 25,900 | | | 12 | 52.5 | 16,000 | 67 | 15,100 | 73.5 | 14,200 | | | | | |
| 14 | 46.8 | 31,256 | 63.2 | 28,464 | 71 | 26,357 | 75.8 | 24,100 | 78.7 | 18,200 | 14 | 45.5 | 12,300 | 63 | 12,250 | 71 | 11,600 | | | 79 | 10,500 | |
| 16 | 38.8 | 26,699 | 59.2 | 26,076 | 68.3 | 24,016 | 73.7 | 22,400 | 77.1 | 16,750 | 16 | 37 | 9850 | 59.5 | 10,150 | 68.5 | 9710 | | | 73.5 | 9280 | |
| 18 | 28.7 | 23,186 | 55.1 | 23,496 | 65.6 | 22,096 | 71.7 | 20,792 | 75.4 | 15,500 | 18 | 26 | 8070 | 55.5 | 8370 | 65.5 | 8230 | | | 71.5 | 7910 | |
| 19.5 | 0 | 21,044 | 51.9 | 21,379 | 63.5 | 20,902 | 70.1 | 19,582 | 74.2 | 14,650 | 19.5 | 0 | 7090 | 52 | 7300 | 63.5 | 7330 | | | 70 | 7060 | |
| 22 | - | - | 46 | 18,471 | 59.9 | 18,629 | 67.4 | 17,872 | 72 | 13,400 | 22 | - | - | 46.5 | 5900 | 60 | 6050 | | | 67.5 | 5900 | |
| 24 | - | - | 40.8 | 16,592 | 56.9 | 16,747 | 65 | 16,300 | 70.3 | 12,500 | 24 | - | - | 41.5 | 5040 | 57 | 5170 | | | 65 | 5150 | |
| 26 | - | - | 36 | 14,600 | 54 | 14,850 | 63 | 14,200 | 68.5 | 11,750 | 26 | - | - | 36 | 4330 | 54 | 4450 | | | 63 | 4520 | |
| 28 | - | - | 29 | 12,750 | 51 | 13,050 | 60.5 | 13,150 | 66.7 | 11,050 | 28 | - | - | 29 | 3740 | 51 | 3850 | | | 60.5 | 3930 | |
| 30 | - | - | 20 | 11,250 | 47.5 | 11,600 | 58.5 | 11,700 | 65.2 | 9800 | 30 | - | - | 20 | 3250 | 47.5 | 3340 | | | 58.5 | 3410 | |
| 31.5 | - | - | 0 | 10,300 | 45 | 10,650 | 56.5 | 10,750 | 63.9 | 9400 | 31.5 | - | - | 0 | 2910 | 45 | 3010 | | | 56.5 | 3080 | |
| 34 | - | - | - | - | 40 | 9350 | 53.5 | 9480 | 61.5 | 8850 | 34 | - | - | - | - | 40 | 2530 | | | 53.5 | 2590 | |
| 36 | - | - | - | - | 36 | 8460 | 51 | 8590 | 59.6 | 8400 | 36 | - | - | - | - | 36 | 2200 | | | 51 | 2260 | |
| 38 | - | - | - | - | 31 | 7680 | 48.5 | 7830 | 57 | 7940 | 38 | - | - | - | - | 31 | 1910 | | | 48.5 | 1960 | |
| 40 | - | - | - | - | 25 | 7000 | 45.5 | 7150 | 55 | 7270 | 40 | - | - | - | - | 25 | 1660 | | | 45.5 | 1700 | |
| 42 | - | - | - | - | 17.5 | 6400 | 42.5 | 6550 | 53 | 6680 | 42 | - | - | - | - | 17.5 | 1410 | | | 42.5 | 1470 | |
| 43.5 | - | - | - | - | 0 | 6000 | 40.5 | 6000 | 51.5 | 6270 | 43.5 | - | - | - | - | 0 | 1230 | | | 40.5 | 1310 | |
| 46 | - | - | - | - | - | - | 36 | 5440 | 48.5 | 5680 | 46 | - | - | - | - | 36 | 1070 | | | 48.5 | 1110 | |
| 48 | - | - | - | - | - | - | 32.5 | 5040 | 46.5 | 5250 | 48 | - | - | - | - | 32.5 | 890 | | | 46.5 | 930 | |
| 50 | - | - | - | - | - | - | 28 | 4680 | 44 | 4860 | 50 | - | - | - | - | 28 | 720 | | | 44 | 780 | |
| 52 | - | - | - | - | - | - | 23 | 4350 | 41.5 | 4510 | 52 | - | - | - | - | 23 | 570 | | | 41.5 | 630 | |
| 54 | - | - | - | - | - | - | 16 | 4040 | 38.5 | 4190 | 54 | - | - | - | - | 16 | 430 | | | 38.5 | 500 | |
| 55.5 | - | - | - | - | - | - | 0 | 3820 | 36.5 | 3960 | 55.5 | - | - | - | - | 0 | 330 | | | 36.5 | 410 | |
| 58 | - | - | - | - | - | - | - | - | 32.5 | 3620 | 58 | - | - | - | - | - | - | | | - | 32.5 | 270 |
| 60 | - | - | - | - | - | - | - | - | 29 | 3370 | 60 | - | - | - | - | - | - | | | - | - | - |
| 62 | - | - | - | - | - | - | - | - | 25 | 3130 | 62 | - | - | - | - | - | - | | | - | - | - |
| 64 | - | - | - | - | - | - | - | - | 20 | 2920 | 64 | - | - | - | - | - | - | | | - | - | - |
| 66 | - | - | - | - | - | - | - | - | 13 | 2720 | 66 | - | - | - | - | - | - | | | - | - | - |
| 67 | - | - | - | - | - | - | - | - | 0 | 2620 | 67 | - | - | - | - | - | - | | | - | - | - |

| MAIN BOOM ON RUBBER | | |
|------------------------|-------------------------|------------------------|
| Any Boom Length | | |
| Radius (ft) | Front Rating (lb) | 360° Rating (lb) |
| 6 | 30,000 | 21,000 |
| 8 | 24,950 | 17,900 |
| 10 | 21,000 | 15,000 |
| 12 | 18,000 | 13,000 |
| 14 | 15,650 | 10,000 |
| 16 | 13,300 | 7920 |
| 18 | 10,900 | 6410 |
| 20 | 9460 | 5780 |
| 22 | 8060 | 4880 |
| 24 | 6960 | 4140 |
| 26 | 6050 | 3520 |
| 28 | 5300 | 2990 |
| 30 | 4670 | 2540 |
| 32 | 4130 | 2160 |
| 34 | 3670 | 1820 |
| 36 | 3260 | 1530 |
| 38 | 2900 | 1270 |
| 40 | 2590 | 1040 |
| 42 | 2300 | 830 |
| 44 | 2280 | 720 |
| 46 | 2050 | 610 |
| 48 | 1840 | 500 |
| 50 | 1650 | 390 |
| 52 | 1480 | 280 |
| 54 | 1320 | - |
| 56 | 1220 | - |
| 58 | 1080 | - |
| 60 | 950 | - |
| 62 | 840 | - |
| 64 | 730 | - |
| 66 | 620 | - |
| 67 | 570 | - |

NOTES:
JIB CAPACITY IS LIMITED BY BOTH STRUCTURAL CAPACITY CHART AND MAIN CAPACITY CHART.

SHADED AREAS ARE GOVERNED BY STRUCTURAL STRENGTH, DO NOT RELY ON TIPPING.

OPERATION OF THIS EQUIPMENT IN EXCESS OF RATING CHARTS AND DISREGARD OF INSTRUCTIONS IS DANGEROUS AND VOIDS WARRANTY.

1) The rated loads are the maximum lift capacities as determined by operating radius, boom length and boom angle. The operating radius is the horizontal distance from a projection of the axis of rotation to the supporting surface, before loading, to the center of vertical hoist line or tackle with load applied.

2) Rated load columns for discrete boom lengths apply when actual boom length is within +/- 1.0 ft of discrete length. When boom length or radius or both are between points listed on capacity chart, the smallest load shown at either the next larger radius or boom length shall be used.

3) For operating radius not shown, use load rating of next larger radius.

4) The rated loads shown on outriggers do not exceed 85% of actual tipping. The rated loads shown on rubber do not exceed 75% of actual tipping. These ratings are based on freely suspended loads with the crane leveled, standing on a firm, uniform supporting surface. Practical working loads depend on supporting surface, operating radius and other factors affecting stability. Hazardous surroundings, climatic conditions, experience of personnel and proper training must all be taken into account by the operator.

| RATING REDUCTIONS FOR LOAD HANDLING DEVICES INSTALLED (lb) | | |
|---|-------------------|-------------|
| | FROM MAIN BOOM | FROM JIB |
| MAIN BLOCK | 475 | N/A |
| HOOK & BALL | 100 | 100 |
| JIB STOWED | 0 | N/A |
| JIB DEPLOYED | 500 | 0 |

MAXIMUM PERMISSIBLE SINGLE LINE PULL
= 12,500 lb

HOIST ROPE: 5/8 in diameter
6 x 19 XIPS IWRC BRIGHT
Min. req'd breaking strength = 45,400 lb

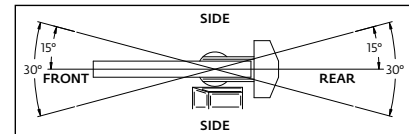

5) The weights of all load handling devices such as hooks, hook blocks, slings, etc., except the hoist rope, shall be considered part of the load. See reduction chart.

6) Ratings on outriggers are for either outriggers fully extended and down or fully retracted and down. Ratings for outriggers fully retracted and down will apply for any intermediate outrigger setting.

7) Ratings on rubber depend on tire capacity, condition of tires and proper inflation pressure (110 psi). When replacing tires, contact Manitowoc for proper specifications. Loads on rubber may be transported at a maximum speed of 2.5 mph on a smooth, hard, level surface with boom retracted to the shortest length possible and centered over front. For 360° ratings on rubber, rear axle oscillation locks must be in place. Do not use jib with crane on rubber.

8) The maximum combined total boom and deck load is 20,000 lb. The maximum deck load only is 30,000 lb.

9) Do not induce any external side loads to boom or jib.

80022135YB

Load chart

| 17 ft JIB CAPACITY ON EXTENDED OUTRIGGERS (lb) | | | | | |
|--|--------------------|--------------------|--------------------|--------------------|---------------------|
| Main Boom Angle (deg) | Jib Offset Angle | | | | |
| | 0° | | 15° | | 30° Any Boom Length |
| | To 55 ft Main Boom | To 71 ft Main Boom | To 55 ft Main Boom | To 71 ft Main Boom | |
| 80 | – | – | 5000 | 5000 | 3500 |
| 75 | 7500 | – | 4400 | 4400 | 3100 |
| 70 | 6100 | – | 3900 | 3900 | 2800 |
| 65 | 5000 | 4600 | 3500 | 3500 | 2550 |
| 60 | 4300 | 3800 | 3150 | 3150 | 2350 |
| 55 | 3800 | 3300 | 2850 | 2850 | 2200 |
| 50 | 3400 | 2900 | 2600 | 2600 | 2100 |
| 45 | 3050 | 2600 | 2400 | 2400 | 2000 |
| 40 | 2800 | 2400 | 2250 | 2250 | 1950 |
| 35 | 2600 | 2150 | 2150 | 2050 | 1900 |
| 30 | 2400 | 1930 | 2080 | 1850 | 1830 |
| 25 | 2300 | 1750 | 2050 | 1720 | – |
| 20 | 2200 | 1600 | 2000 | 1590 | – |
| 15 | 2100 | 1500 | 1950 | 1520 | – |
| 10 | 2050 | 1460 | – | – | – |
| 5 | 2020 | 1450 | – | – | – |
| 0 | 2000 | 1440 | – | – | – |

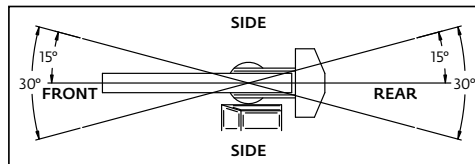

1) The rated loads are the maximum lift capacities as determined by operating radius, boom length and boom angle. The operating radius is the horizontal distance from a projection of the axis of rotation to the supporting surface, before loading, to the center of vertical hoist line or tackle with load applied.

2) Rated load columns for discrete boom lengths apply when actual boom length is within +/- 1.0 ft of discrete length. When boom length or radius or both are between points listed on capacity chart, the smallest load shown at either the next larger radius or boom length shall be used.

3) For operating radius not shown, use load rating of next larger radius.

4) The rated loads shown on outriggers do not exceed 85% of actual tipping. The rated loads shown on rubber do not exceed 75% of actual tipping. These ratings are based on freely suspended loads with the crane leveled, standing on a firm, uniform supporting surface. Practical working loads depend on supporting surface, operating radius and other factors affecting stability. Hazardous surroundings, climatic conditions, experience of personnel and proper training must all be taken into account by the operator.

5) The weights of all load handling devices such as hooks, hook blocks, slings, etc., except the hoist rope, shall be considered part of the load. See reduction chart.

6) Ratings on outriggers are for either outriggers fully extended and down or fully retracted and down. Ratings for outriggers fully retracted and down will apply for any intermediate outrigger setting.

7) Ratings on rubber depend on tire capacity, condition of tires and proper inflation pressure (110 psi). When replacing tires, contact Manitowoc for proper specifications. Loads on rubber may be transported at a maximum speed of 2.5 mph on a smooth, hard, level surface with boom retracted to the shortest length possible and centered over front. For 360° ratings on rubber, rear axle oscillation locks must be in place. Do not use jib with crane on rubber.

8) The maximum combined total boom and deck load is 20,000 lb. The maximum deck load only is 30,000 lb.

9) Do not induce any external side loads to boom or jib.

80022135YB

DIN/ISO range diagram

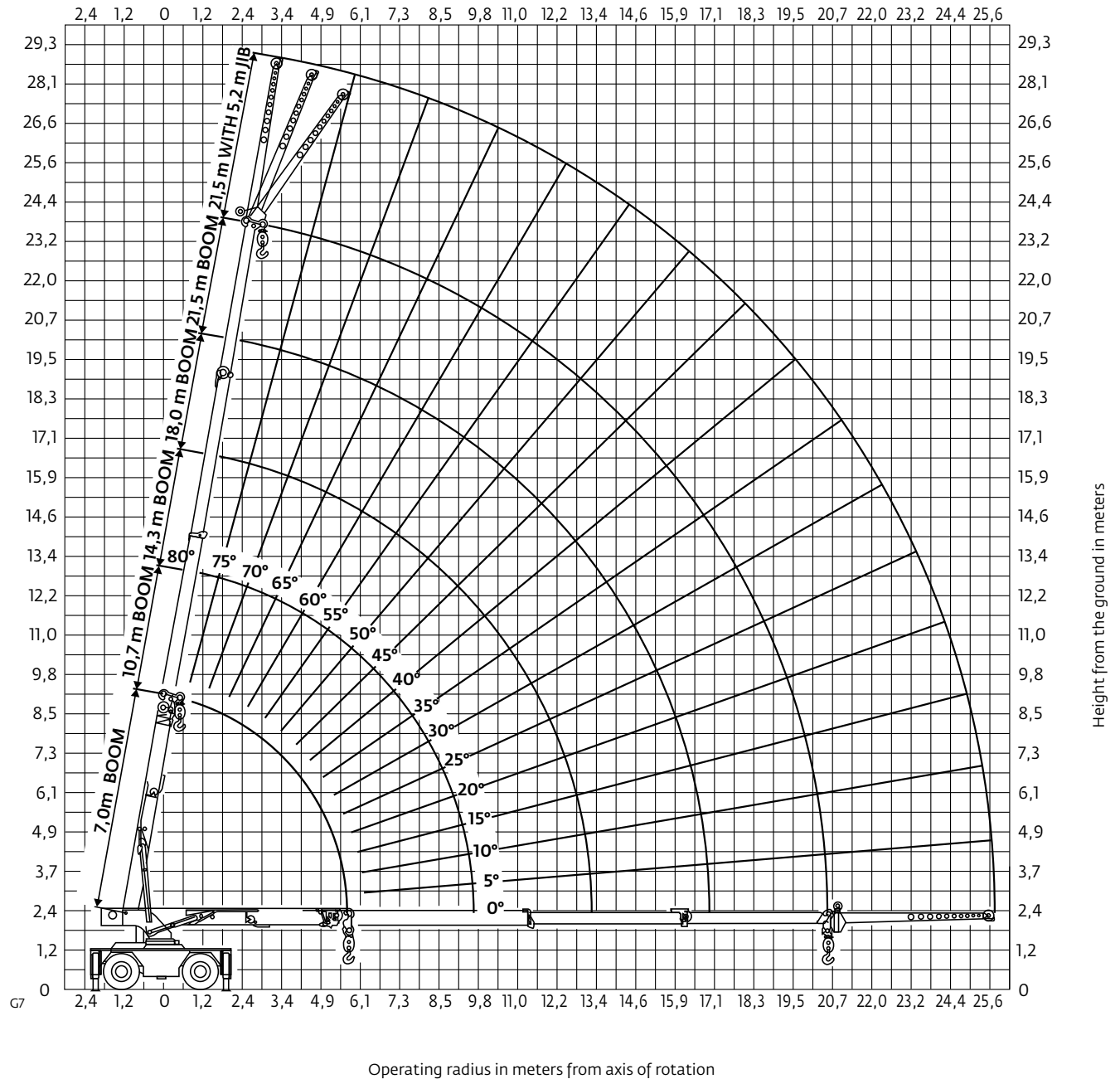

THIS CHART IS ONLY A GUIDE AND SHOULD NOT BE USED TO OPERATE THE CRANE.

The individual crane's load chart, operating instructions and other instructional plates must be read and understood prior to operating the crane.

DIN/ISO load chart

| MAIN BOOM LOAD RATINGS ON OUTRIGGERS Extended and Down 360° or Retracted and Down Front/Rear | | | | | | | | | | MAIN BOOM LOAD RATINGS ON OUTRIGGERS Retracted and Down 360° | | | | | | | | | | | |
|---|------------------------|-----------------------|------------------------|-----------------------|------------------------|-----------------------|------------------------|-----------------------|------------------------|---|---------------|------------------------|-----------------------|------------------------|-----------------------|------------------------|-----------------------|------------------------|-----------------------|------------------------|-----------------------|
| Radius (m) | 7,0 m Boom | | 10,7 m Boom | | 14,3 m Boom | | 18,0 m Boom | | 21,5 m Boom | | Radius (m) | 7,0 m Boom | | 10,7 m Boom | | 14,3 m Boom | | 18,0 m Boom | | 21,5 m Boom | |
| | Boom Angle (deg) | Rated Load (kg) | Boom Angle (deg) | Rated Load (kg) | Boom Angle (deg) | Rated Load (kg) | Boom Angle (deg) | Rated Load (kg) | Boom Angle (deg) | Rated Load (kg) | | Boom Angle (deg) | Rated Load (kg) | Boom Angle (deg) | Rated Load (kg) | Boom Angle (deg) | Rated Load (kg) | Boom Angle (deg) | Rated Load (kg) | Boom Angle (deg) | Rated Load (kg) |
| 2,6 | 64,5 | 22 650 | 73,5 | 15 550 | 78,5 | 15 225 | 80 | 12 600 | | | 2,6 | 63,5 | 10 675 | 73 | 9495 | 78 | 8490 | 79,5 | 6580 | | |
| 3,0 | 60 | 17 575 | 71 | 15 650 | 76,5 | 14 975 | 78 | 11 725 | | | 3,0 | 59 | 8805 | 70,5 | 7955 | 76 | 7220 | 77,5 | 5215 | | |
| 3,7 | 54 | 15 825 | 67 | 14 250 | 74 | 13 275 | 78 | 10 925 | | | 3,7 | 52,5 | 6625 | 67 | 6100 | 73,5 | 5640 | 75,5 | 4370 | | |
| 4,3 | 47 | 14 175 | 63,5 | 12 900 | 71 | 11 950 | 76 | 10 925 | | 8255 | 4,3 | 45,5 | 5390 | 63 | 5010 | 71 | 4680 | 73,5 | 3715 | 77 | 4095 |
| 4,9 | 39 | 12 100 | 59,5 | 11 825 | 68,5 | 10 875 | 74 | 10 150 | 79 | 7595 | 4,9 | 37 | 4430 | 59,5 | 4195 | 68,5 | 3950 | 71,5 | 3190 | 75,5 | 3030 |
| 5,5 | 29 | 10 500 | 55,5 | 10 650 | 66 | 10 000 | 72 | 9365 | 75,5 | 7030 | 5,5 | 26 | 3645 | 55,5 | 3570 | 65,5 | 3375 | 70 | 2900 | 74 | 2760 |
| 5,9 | 0 | 9545 | 52 | 9695 | 63,5 | 9070 | 70,5 | 8510 | 74,5 | 6645 | 5,9 | 0 | 3245 | 52 | 3225 | 63,5 | 3055 | 67,5 | 2415 | 72 | 2305 |
| 6,7 | - | - | 46 | 7905 | 60 | 7575 | 67,5 | 7155 | 72 | 6075 | 6,7 | - | - | 46,5 | 2665 | 60 | 2535 | 65 | 2115 | 70 | 2025 |
| 7,3 | - | - | 41 | 6785 | 57 | 6715 | 65 | 6365 | 70,5 | 5670 | 7,3 | - | - | 41,5 | 2295 | 57 | 2215 | 63 | 1860 | 68,5 | 1785 |
| 7,9 | - | - | 36 | 5905 | 54 | 5965 | 63 | 5710 | 68,5 | 5330 | 7,9 | - | - | 36 | 1975 | 54 | 1945 | 60,5 | 1640 | 66,5 | 1580 |
| 8,5 | - | - | 29 | 5215 | 51 | 5205 | 60,5 | 5155 | 67 | 4945 | 8,5 | - | - | 29 | 1710 | 51 | 1715 | 58,5 | 1450 | 65 | 1395 |
| 9,1 | - | - | 20 | 4640 | 47,5 | 4660 | 58,5 | 4625 | 65,5 | 4445 | 9,1 | - | - | 20 | 1490 | 47,5 | 1515 | 56,5 | 1310 | 63,5 | 1260 |
| 9,6 | - | - | 0 | 4255 | 45 | 4270 | 56,5 | 4240 | 64 | 4180 | 9,6 | - | - | 0 | 1320 | 45 | 1365 | 53,5 | 1110 | 61 | 1070 |
| 10,4 | - | - | - | - | 40 | 3725 | 53,5 | 3725 | 61,5 | 3695 | 10,4 | - | - | - | - | 40 | 1140 | 51 | 980 | 59 | 945 |
| 11,0 | - | - | - | - | 36 | 3380 | 51 | 3395 | 60 | 3375 | 11,0 | - | - | - | - | 36 | 995 | 48,5 | 865 | 57 | 830 |
| 11,6 | - | - | - | - | 31 | 3080 | 48,5 | 3105 | 57 | 3090 | 11,6 | - | - | - | - | 31 | 865 | 45,5 | 760 | 55 | 730 |
| 12,2 | - | - | - | - | 25 | 2815 | 45,5 | 2840 | 55 | 2845 | 12,2 | - | - | - | - | 25 | 755 | 42,5 | 665 | 53 | 635 |
| 12,8 | - | - | - | - | 17,5 | 2590 | 42,5 | 2605 | 53 | 2625 | 12,8 | - | - | - | - | 17,5 | 640 | 40,5 | 595 | 51,5 | 570 |
| 13,3 | - | - | - | - | 0 | 2440 | 40,5 | 2440 | 51,5 | 2465 | 13,3 | - | - | - | - | 0 | 560 | 36 | 490 | 48,5 | 475 |
| 14,0 | - | - | - | - | - | - | 36 | 2210 | 48,5 | 2225 | 14,0 | - | - | - | - | - | - | 32,5 | 405 | 46,5 | 405 |
| 14,6 | - | - | - | - | - | - | 32,5 | 2040 | 46,5 | 2055 | 14,6 | - | - | - | - | - | - | 28 | 330 | 44 | 340 |
| 15,2 | - | - | - | - | - | - | 28 | 1890 | 44 | 1900 | 15,2 | - | - | - | - | - | - | 23 | 260 | 41,5 | 280 |
| 15,8 | - | - | - | - | - | - | 23 | 1750 | 41,5 | 1760 | 15,8 | - | - | - | - | - | - | 16 | 190 | 38,5 | 215 |
| 16,5 | - | - | - | - | - | - | 16 | 1600 | 38,5 | 1615 | 16,5 | - | - | - | - | - | - | 0 | 150 | 36,5 | 180 |
| 16,9 | - | - | - | - | - | - | 0 | 1515 | 36,5 | 1535 | 16,9 | - | - | - | - | - | - | - | - | 32,5 | 115 |
| 17,7 | - | - | - | - | - | - | - | - | 32,5 | 1395 | 17,7 | - | - | - | - | - | - | - | - | - | - |
| 18,3 | - | - | - | - | - | - | - | - | 29 | 1295 | 18,3 | - | - | - | - | - | - | - | - | - | - |
| 18,9 | - | - | - | - | - | - | - | - | 25 | 1210 | 18,9 | - | - | - | - | - | - | - | - | - | - |
| 19,5 | - | - | - | - | - | - | - | - | 20 | 1125 | 19,5 | - | - | - | - | - | - | - | - | - | - |
| 20,1 | - | - | - | - | - | - | - | - | 13 | 1045 | 20,1 | - | - | - | - | - | - | - | - | - | - |
| 20,4 | - | - | - | - | - | - | - | - | 0 | 1010 | 20,4 | - | - | - | - | - | - | - | - | - | - |

| MAIN BOOM ON RUBBER | | |
|------------------------|-------------------------|------------------------|
| Any Boom Length | | |
| Radius (m) | Front Rating (kg) | 360° Rating (kg) |
| 1,8 | 13 600 | 9525 |
| 2,6 | 11 300 | 6875 |
| 3,0 | 9105 | 5040 |
| 3,7 | 6525 | 4070 |
| 4,3 | 5530 | 3445 |
| 4,9 | 4435 | 2950 |
| 5,5 | 3880 | 2545 |
| 6,1 | 3425 | 2210 |
| 6,7 | 3045 | 1930 |
| 7,3 | 2710 | 1685 |
| 7,9 | 2350 | 1480 |
| 8,5 | 2050 | 1255 |
| 9,1 | 1800 | 1055 |
| 9,8 | 1550 | 855 |
| 10,4 | 1365 | 705 |
| 11,0 | 1205 | 575 |
| 11,6 | 1065 | 460 |
| 12,2 | 940 | 360 |
| 12,8 | 830 | 265 |
| 13,4 | 820 | 230 |
| 14,0 | 730 | 195 |
| 14,6 | 650 | 160 |
| 15,2 | 570 | 125 |
| 15,8 | 505 | 90 |
| 16,5 | 430 | - |
| 17,1 | 390 | - |
| 17,7 | 340 | - |
| 18,3 | 290 | - |
| 18,9 | 240 | - |
| 19,5 | 195 | - |
| 20,1 | 155 | - |
| 20,4 | 135 | - |

NOTES:
JIB CAPACITY IS LIMITED BY BOTH STRUCTURAL CAPACITY CHART AND MAIN CAPACITY CHART.

SHADED AREAS ARE GOVERNED BY STRUCTURAL STRENGTH, DO NOT RELY ON TIPPING.

OPERATION OF THIS EQUIPMENT IN EXCESS OF RATING CHARTS AND DISREGARD OF INSTRUCTIONS IS DANGEROUS AND VOIDS WARRANTY.

1) The rated loads are the maximum lift capacities as determined by operating radius, boom length and boom angle. The operating radius is the horizontal distance from a projection of the axis of rotation to the supporting surface, before loading, to the center of vertical hoist line or tackle with load applied.

2) Rated load columns for discrete boom lengths apply when actual boom length is within +/- 0,3 m of discrete length. When boom length or radius or both are between points listed on capacity chart, the smallest load shown at either the next larger radius or boom length shall be used.

3) For operating radius not shown, use load rating of next larger radius.

4) The rated loads shown on outriggers do not exceed 85% of actual tipping. The rated loads shown on rubber do not exceed 75% of actual tipping. These ratings are based on freely suspended loads with the crane leveled, standing on a firm, uniform supporting surface. Practical working loads depend on supporting surface, operating radius and other factors affecting stability. Hazardous surroundings, climatic conditions, experience of personnel and proper training must all be taken into account by the operator.

| RATING REDUCTIONS FOR LOAD HANDLING DEVICES INSTALLED (kg) | | |
|---|-------------------|-------------|
| | FROM MAIN BOOM | FROM JIB |
| MAIN BLOCK | 215 | N/A |
| HOOK & BALL | 50 | 50 |
| JIB STOWED | 0 | N/A |
| JIB DEPLOYED | 230 | 0 |

MAXIMUM PERMISSIBLE SINGLE LINE PULL = 5670 kg

HOIST ROPE: 16 mm diameter
8 x 26 XIPS IWRC BRIGHT
Min. req'd breaking strength = 258,9 kN

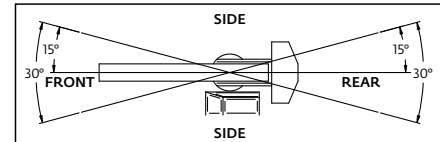

5) The weights of all load handling devices such as hooks, hook blocks, slings, etc., except the hoist rope, shall be considered part of the load. See reduction chart.

6) Ratings on outriggers are for either outriggers fully extended and down or fully retracted and down. Ratings for outriggers fully retracted and down will apply for any intermediate outrigger setting.

7) Ratings on rubber depend on tire capacity, condition of tires and proper inflation pressure (7.6 bar). When replacing tires, contact Manitowoc for proper specifications. Loads on rubber may be transported at a maximum speed of 4,0 km/h on a smooth, hard, level surface with boom retracted to the shortest length possible and centered over front. For 360° ratings on rubber, rear axle oscillation locks must be in place. Do not use jib with crane on rubber.

8) The maximum combined total boom and deck load is 9070 kg. The maximum deck load only is 13 610 kg.

9) Do not induce any external side loads to boom or jib.

80024905YB

DIN/ISO load chart

| 5,2 m JIB CAPACITY ON EXTENDED OUTRIGGERS (kg) | | | | | |
|--|---------------------|---------------------|---------------------|---------------------|---------------------|
| Main Boom Angle (deg) | Jib Offset Angle | | | | 30° Any Boom Length |
| | 0° | | 15° | | |
| | To 18,0 m Main Boom | To 21,5 m Main Boom | To 18,0 m Main Boom | To 21,5 m Main Boom | |
| 80 | — | — | 2270 | 2270 | 1590 |
| 75 | 3400 | — | 2000 | 2000 | 1410 |
| 70 | 2770 | — | 1770 | 1770 | 1270 |
| 65 | 2270 | 2090 | 1590 | 1590 | 1160 |
| 60 | 1950 | 1720 | 1430 | 1430 | 1070 |
| 55 | 1720 | 1500 | 1290 | 1290 | 1000 |
| 50 | 1540 | 1320 | 1180 | 1180 | 0950 |
| 45 | 1380 | 1180 | 1090 | 1090 | 0910 |
| 40 | 1270 | 1090 | 1020 | 1020 | 0880 |
| 35 | 1180 | 0980 | 0980 | 0930 | 0860 |
| 30 | 1090 | 0880 | 0940 | 0840 | 0830 |
| 25 | 1040 | 0790 | 0930 | 0780 | — |
| 20 | 1000 | 0730 | 0910 | 0720 | — |
| 15 | 0950 | 0680 | 0880 | 0690 | — |
| 10 | 0930 | 0660 | — | — | — |
| 5 | 0920 | 0660 | — | — | — |
| 0 | 0910 | 0650 | — | — | — |

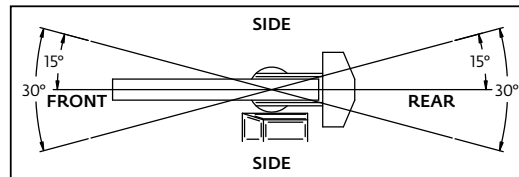

1) The rated loads are the maximum lift capacities as determined by operating radius, boom length and boom angle. The operating radius is the horizontal distance from a projection of the axis of rotation to the supporting surface, before loading, to the center of vertical hoist line or tackle with load applied.

2) Rated load columns for discrete boom lengths apply when actual boom length is within +/- 0,3 m of discrete length. When boom length or radius or both are between points listed on capacity chart, the smallest load shown at either the next larger radius or boom length shall be used.

3) For operating radius not shown, use load rating of next larger radius.

4) The rated loads shown on outriggers do not exceed 85% of actual tipping. The rated loads shown on rubber do not exceed 75% of actual tipping. These ratings are based on freely suspended loads with the crane leveled, standing on a firm, uniform supporting surface. Practical working loads depend on supporting surface, operating radius and other factors affecting stability. Hazardous surroundings, climatic conditions, experience of personnel and proper training must all be taken into account by the operator.

5) The weights of all load handling devices such as hooks, hook blocks, slings, etc., except the hoist rope, shall be considered part of the load. See reduction chart.

6) Ratings on outriggers are for either outriggers fully extended and down or fully retracted and down. Ratings for outriggers fully retracted and down will apply for any intermediate outrigger setting.

7) Ratings on rubber depend on tire capacity, condition of tires and proper inflation pressure (7.6 bar). When replacing tires, contact Manitowoc for proper specifications. Loads on rubber may be transported at a maximum speed of 4,0 km/h on a smooth, hard, level surface with boom retracted to the shortest length possible and centered over front. For 360° ratings on rubber, rear axle oscillation locks must be in place. Do not use jib with crane on rubber.

8) The maximum combined total boom and deck load is 9070 kg. The maximum deck load only is 13 610 kg.

9) Do not induce any external side loads to boom or jib.

80024905YB

Symbols glossary



Axles



Counterweight



Grade



Outriggers



Boom



Drive



Heavy duty jib



Radius



Boom elevation



Electrical system



Hoist



Rotation



Boom extension



Engine



Hookblock



Speed



Boom length



Extension



Hydraulic system



Steering



Boom nose



Frame



Lights



Suspension



Brakes



Fuel tank capacity



Oil



Swing



Cab



Gear



Outrigger controls



Tires



Transmission

Manitowoc Cranes

Regional headquarters

Americas

Manitowoc, Wisconsin, USA

Tel: +1 920 684 6621

Fax: +1 920 683 6277

Shady Grove, Pennsylvania, USA

Tel: +1 717 597 8121

Fax: +1 717 597 4062

Europe, Middle East, Africa

Ecully, France

Tel: +33 (0)4 72 18 20 20

Fax: +33 (0)4 72 18 20 00

China

Shanghai, China

Tel: +86 21 6457 0066

Fax: +86 21 6457 4955

Greater Asia-Pacific

Singapore

Tel: +65 6264 1188

Fax: +65 6862 4040

Regional offices

Americas

Brazil

Alphaville

Mexico

Monterrey

Chile

Santiago

Europe, Middle East,

Africa

Czech Republic

Netvorice

France

Baudemont

Cergy

Decines

Germany

Langenfeld

Hungary

Budapest

Italy

Lainate

Netherlands

Breda

Poland

Warsaw

Portugal

Baltar

Russia

Moscow

South Africa

Johannesburg

U.A.E.

Dubai

U.K.

Buckingham

China

Beijing

Chengdu

Guangzhou

Xian

Greater Asia-Pacific

Australia

Brisbane

Melbourne

Sydney

India

Chennai

Delhi

Hyderabad

Pune

Korea

Seoul

Philippines

Makati City

Singapore

Factories

Brazil

Passo Fundo

China

TaiAn

Zhangjiagang

France

Charlieu

Moulins

Germany

Wilhelmshaven

India

Pune

Italy

Niella Tanaro

Portugal

Baltar

Fânzeres

Slovakia

Saris

USA

Manitowoc

Port Washington

Shady Grove

This document is non-contractual. Constant improvement and engineering progress make it necessary that we reserve the right to make specification, equipment, and price changes without notice. Illustrations shown may include optional equipment and accessories and may not include all standard equipment.